

● **FEATURES**

Ideal for Medium Power Amplification and Switching

● **MECHANICAL DATA**

Case: SOT-363 Plastic

Case material: "Green" molding compound, UL flammability classification 94V-0, (No Br. Sb. Cl)

Lead Free in RoHS 2002/95/EC Compliant

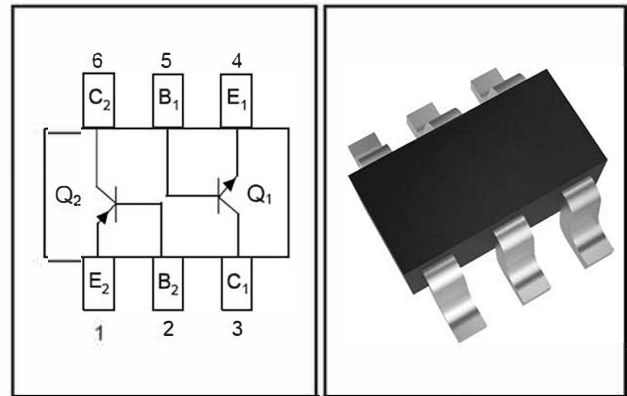

● **NPN - Maximum Ratings @ $T_A = 25^\circ\text{C}$**

Characteristic	Symbol	Value	Unit
Collector-Base Voltage	V_{CBO}	180	V
Collector-Emitter Voltage	V_{CEO}	160	V
Emitter-Base Voltage	V_{EBO}	6	V
Collector Current - Continuous	I_C	600	mA

● **PNP - Maximum Ratings @ $T_A = 25^\circ\text{C}$**

Characteristic	Symbol	Value	Unit
Collector-Base Voltage	V_{CBO}	-160	V
Collector-Emitter Voltage	V_{CEO}	-150	V
Emitter-Base Voltage	V_{EBO}	-5	V
Collector Current - Continuous	I_C	-600	mA

● **Thermal Characteristics**

Characteristic	Symbol	Value	Unit
Total Power Dissipation FR-5 board	P_D	225	mW
Junction Temperature	T_J	150	$^\circ\text{C}$
Storage Temperature Range	T_{STG}	-55~+150	$^\circ\text{C}$

● Q1 - Electrical Characteristics @ $T_A = 25^\circ\text{C}$ unless otherwise specified

Characteristic	Test Condition	Symbol	Min.	Typ.	Max.	Unit
Collector-base breakdown voltage	$I_C=100\mu\text{A}, I_E=0$	V_{CBO}	180			V
Collector-emitter breakdown voltage	$I_C=1\text{mA}, I_B=0$	V_{CEO}	160			V
Emitter-base breakdown voltage	$I_E=100\mu\text{A}, I_C=0$	V_{EBO}	5			V
Collector-base cut-off current	$V_{CB}=120\text{V}, I_E=0$	I_{CBO}			0.05	μA
Emitter-base cut-off current	$V_{EB}=4\text{V}, I_C=0$	I_{EBO}			0.05	μA
DC current gain	$V_{CE}=5\text{V}, I_C=1\text{mA}$	h_{FE1}	80			
	$V_{CE}=5\text{V}, I_C=10\text{mA}$	h_{FE2}	100		300	
	$V_{CE}=5\text{V}, I_C=50\text{mA}$	h_{FE3}	30			
Collector-emitter saturation voltage	$I_C=10\text{mA}, I_B=1\text{mA}$	$V_{CE(sat)1}$			0.15	V
	$I_C=50\text{mA}, I_B=5\text{mA}$	$V_{CE(sat)2}$			0.5	V
Base-emitter saturation voltage	$I_C=10\text{mA}, I_B=1\text{mA}$	$V_{BE(sat)1}$			1	V
	$I_C=50\text{mA}, I_B=5\text{mA}$	$V_{BE(sat)2}$			1	V

● Q2 - Electrical Characteristics @ $T_A = 25^\circ\text{C}$ unless otherwise specified

Characteristic	Test Condition	Symbol	Min.	Typ.	Max.	Unit
Collector-base breakdown voltage	$I_C=-100\mu\text{A}, I_E=0$	V_{CBO}	-160			V
Collector-emitter breakdown voltage	$I_C=-1\text{mA}, I_B=0$	V_{CEO}	-150			V
Emitter-base breakdown voltage	$I_E=-100\mu\text{A}, I_C=0$	V_{EBO}	-5			V
Collector-base cut-off current	$V_{CB}=-120\text{V}, I_E=0$	I_{CBO}			-0.05	μA
DC current gain	$V_{CE}=-5\text{V}, I_C=-1\text{mA}$	h_{FE1}	50			
	$V_{CE}=-5\text{V}, I_C=-10\text{mA}$	h_{FE2}	100		300	
	$V_{CE}=-5\text{V}, I_C=-50\text{mA}$	h_{FE3}	50			
Collector-emitter saturation voltage	$I_C=-10\text{mA}, I_B=-1\text{mA}$	$V_{CE(sat)1}$			-0.2	V
	$I_C=-50\text{mA}, I_B=-5\text{mA}$	$V_{CE(sat)2}$			-0.5	V
Base-emitter saturation voltage	$I_C=-10\text{mA}, I_B=-1\text{mA}$	$V_{BE(sat)1}$			-1	V
	$I_C=-50\text{mA}, I_B=-5\text{mA}$	$V_{BE(sat)2}$			-1	V

● Small Signal Characteristics

Characteristic	Test Condition	Symbol	Min.	Typ.	Max.	Unit
Transition frequency	$V_{CE}=-10\text{V}, I_C=-10\text{mA}, f=100\text{MHz}$	f_T	100		300	MHz
Collector output capacitance	$V_{CB}=-10\text{V}, I_E=0, f=1\text{MHz}$	C_{ob}			6	pF
Noise Figure	$V_{CE}=-5\text{V}, I_C=-0.2\text{mA}, R_S=10\text{K}\Omega, f=1\text{kHz}$	NF			8	dB

SOT-363 Outline Dimension

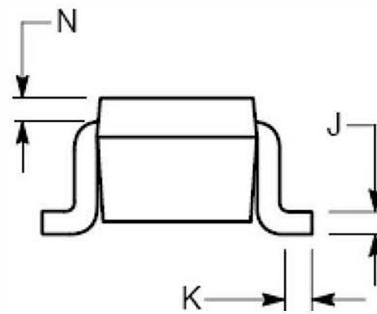
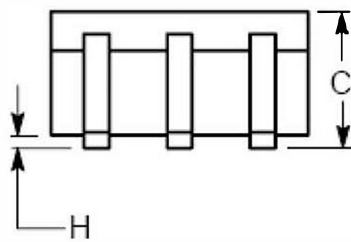
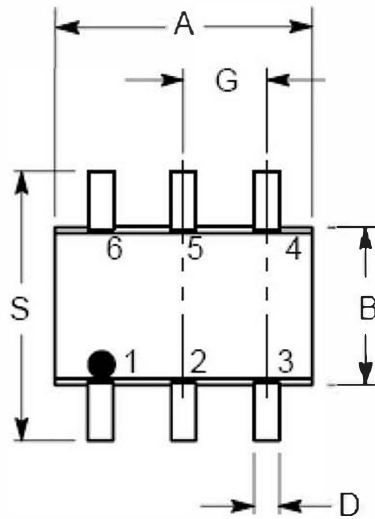

Symbol	Dimension In Millimeters	
	Min	Max.
A	1.89	2.20
B	1.15	1.35
C	0.80	1.10
D	0.10	0.30
G	0.65 BSC	
H	---	0.10
J	0.10	0.25
K	0.10	0.30
N	0.20 REF	
S	2.00	2.20

Q1 TYPICAL PNP CHARACTERISTICS

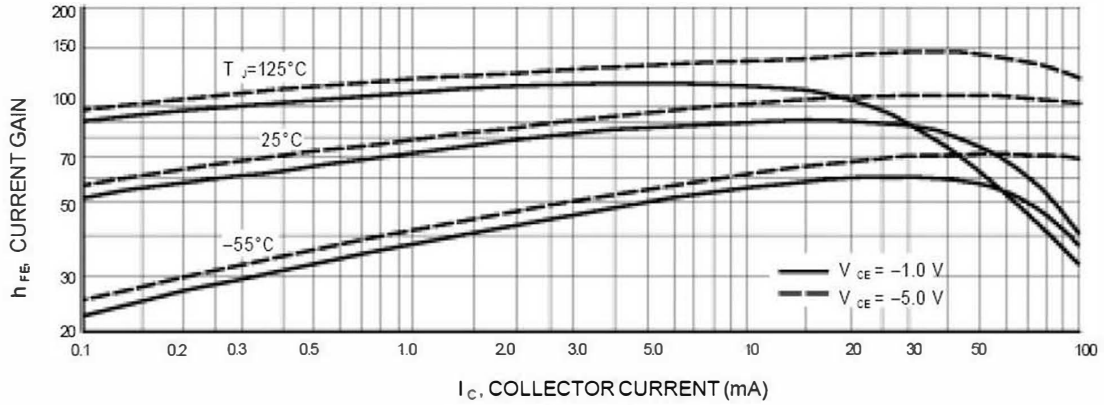

Figure 1. DC Current Gain

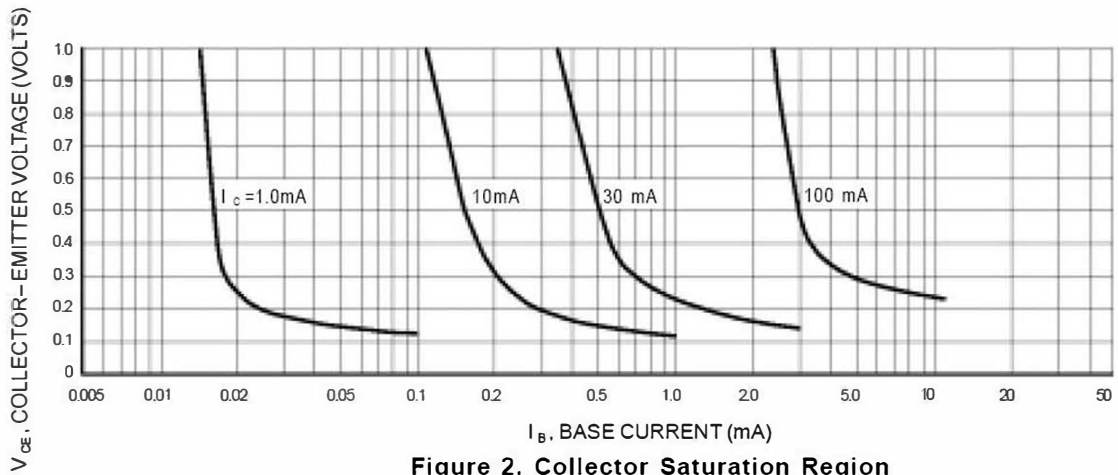

Figure 2. Collector Saturation Region

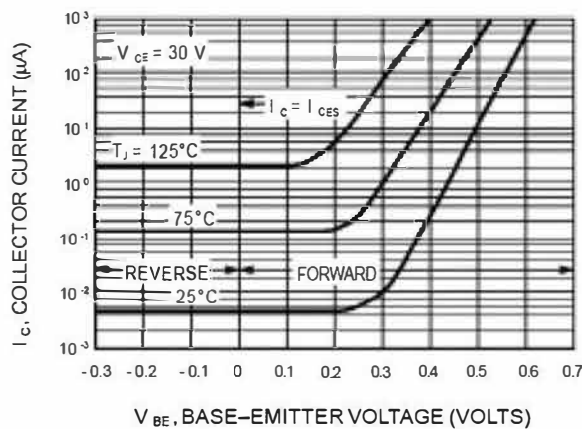

Figure 3. Collector Cut-Off Region

Q1 TYPICAL PNP CHARACTERISTICS

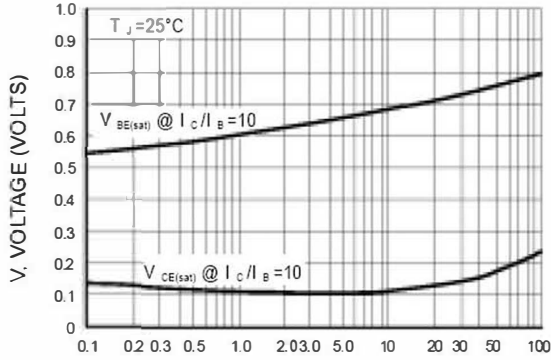

Figure 4. "On" Voltages

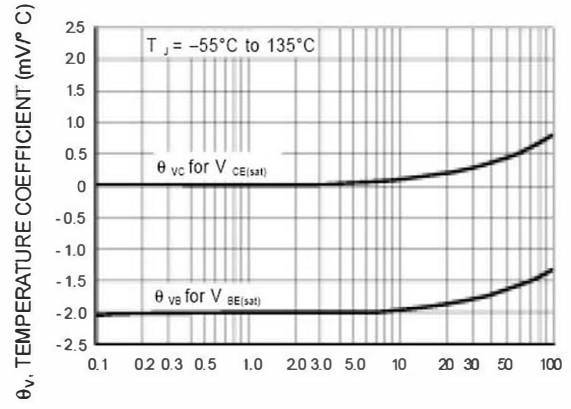

Figure 5. Temperature Coefficients

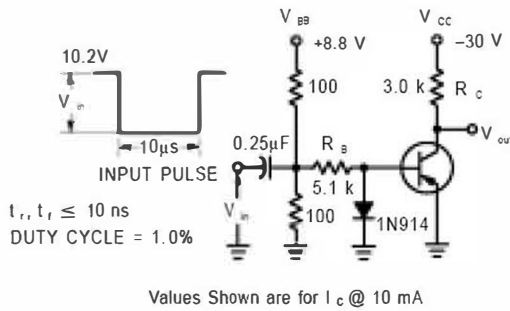

Figure 6. Switching Time Test Circuit

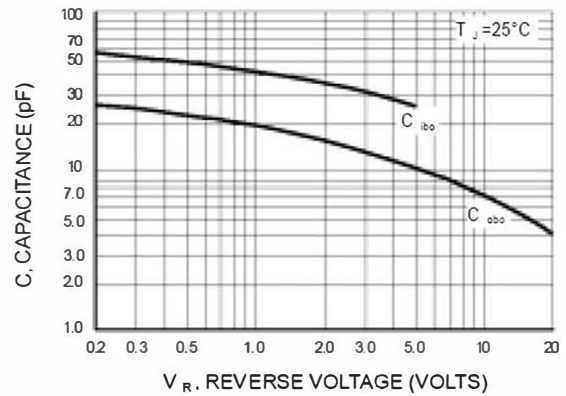

Figure 7. Capacitances

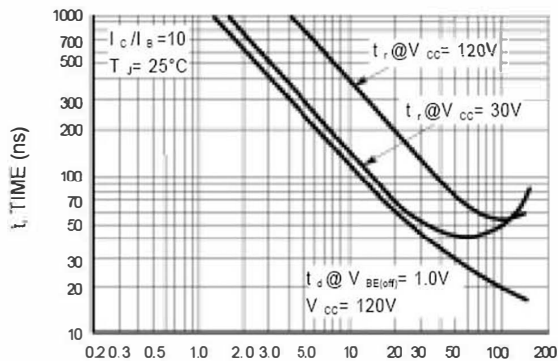

Figure 8. Turn-On Time

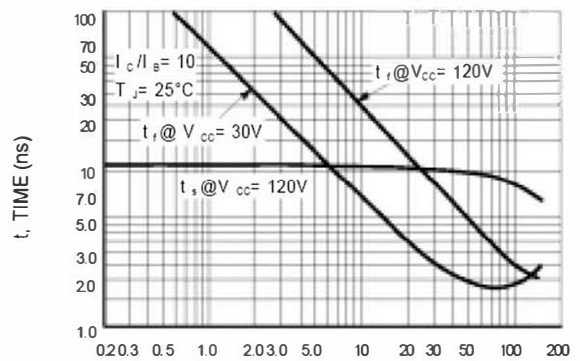

Figure 9. Turn-Off Time

Q2 TYPICAL NPN CHARACTERISTICS

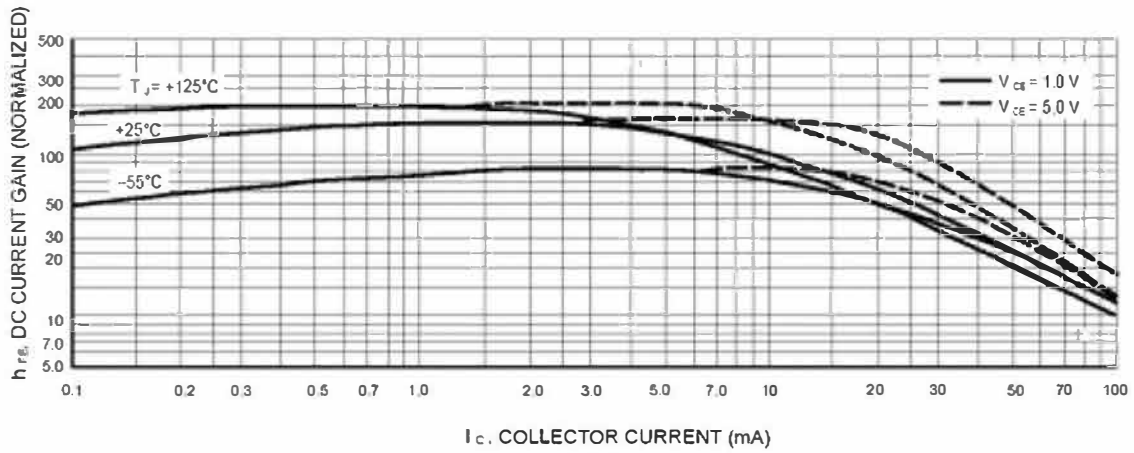

Figure 10. DC Current Gain

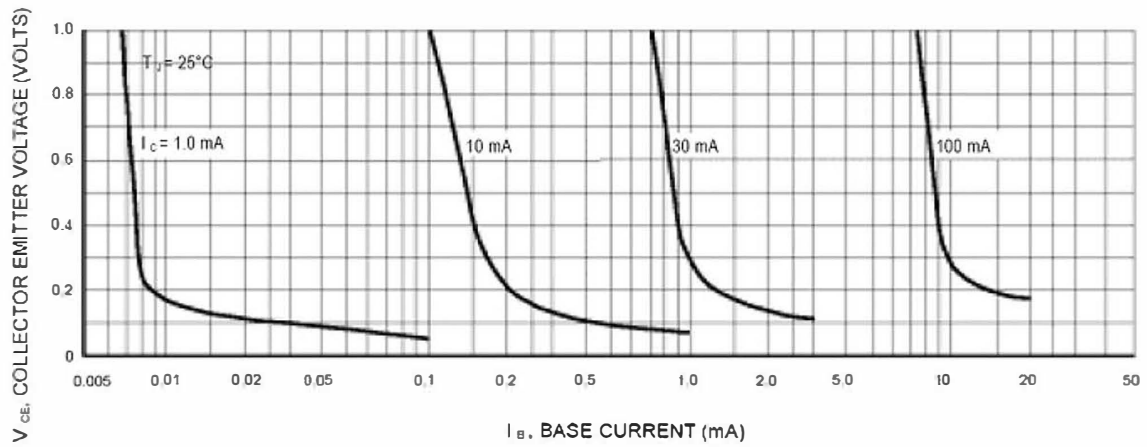

Figure 11. Collector Saturation Region

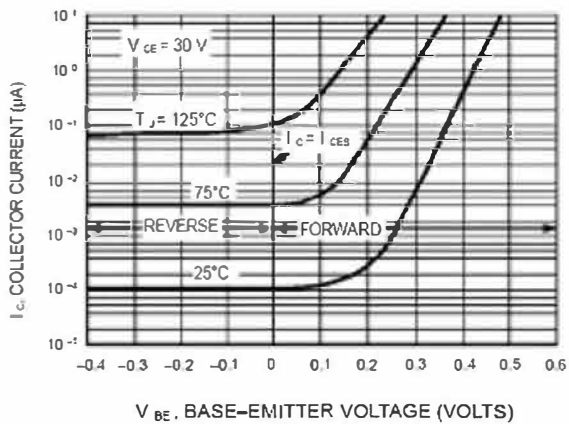

Figure 12. Collector Cut-Off Region

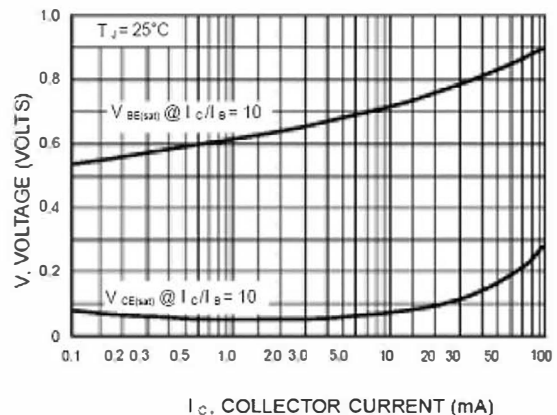

Figure 13. "On" Voltages

Q3 TYPICAL NPN CHARACTERISTICS

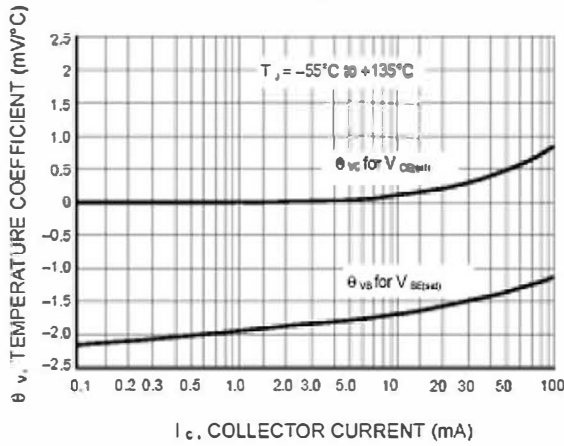
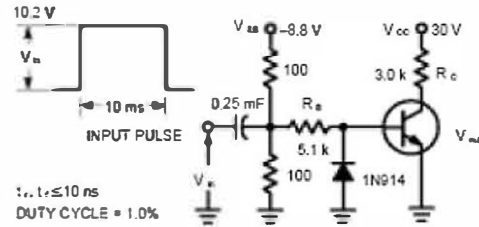

Figure 14. Temperature Coefficients



Values Shown are for $I_c @ 10\text{ mA}$
Figure 15. Switching Time Test Circuit

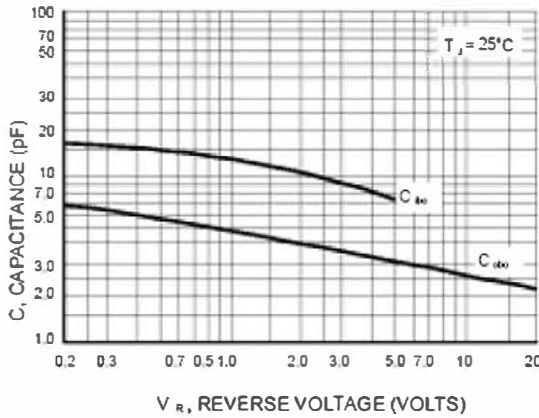

Figure 16. Capacitances Figure

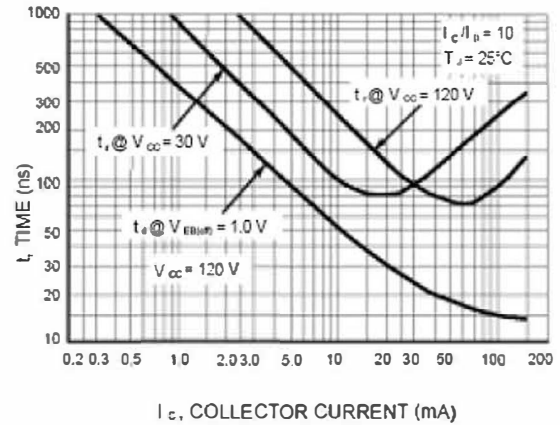

Figure 17. Turn-On Time

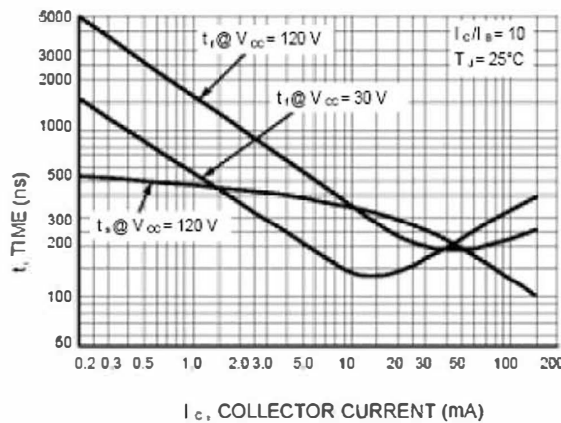

Figure 18. Turn-Off Time