

SOT-23 Plastic-Encapsulate NPN Transistors

1. Features

- Complementary to S9012S
- Power dissipation of 300mW
- High stability and high reliability

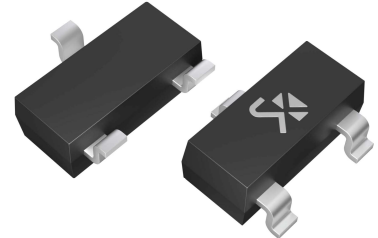

SOT-23

2. Mechanical Data

- SOT-23 Small Outline Plastic Package
- Epoxy UL: 94V-0
- Mounting Position: Any

Pin configuration

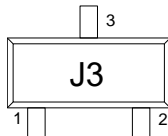
Pin	Function	Outline
1	Base	
2	Emitter	
3	Collector	

Specification

Absolute Maximum Rating & Thermal Characteristics

Ratings at 25 °C ambient temperature unless otherwise specified.

Parameters	Symbol	Value	Unit
Collector-Base Voltage	$V_{CBO}$	40	V
Collector-Emitter Voltage	$V_{CEO}$	30	V
Emitter-Base Voltage	$V_{EBO}$	6	V
Collector Current-Continuous	$I_C$	500	mA
Collector Power Dissipation	$P_C$	300	mW
Junction Temperature	$T_j$	150	°C
Storage Temperature	$T_{STG}$	-55~150	°C
Thermal resistance From junction to ambient	$R_{\theta JA}$	416	°C/W

Electrical Characteristics (At  $T_A = 25^\circ\text{C}$  unless otherwise specified)

Parameters	Symbols	Test Condition	Limits			
			Min	Typ	Max	Unit
Collector-base breakdown voltage	$V_{(BR)CBO}$	$I_C=50\mu\text{A}, I_E=0$	70			V
Collector-emitter breakdown voltage	$V_{(BR)CEO}$	$I_C=1\text{mA}, I_B=0$	30			V
Emitter-base breakdown voltage	$V_{(BR)EBO}$	$I_E=50\mu\text{A}, I_C=0$	6			V
Collector cut-off current	$I_{CEO}$	$V_{CE}=20\text{V}, I_B=0$			100	nA
	$I_{CBO}$	$V_{CB}=40\text{V}, I_E=0$			100	
Emitter cut-off current	$I_{EBO}$	$V_{EB}=5\text{V}, I_C=0$			100	nA
DC current gain	$h_{FE}$	$V_{CE}=1\text{V}, I_C=50\text{mA}$	85		400	
Collector-emitter saturation voltage	$V_{CE(sat)}$	$I_C=500\text{mA}, I_B=50\text{mA}$			0.60	V
Base-emitter saturation voltage	$V_{BE(sat)}$	$I_C=500\text{mA}, I_B=50\text{mA}$			1.20	V
Transition frequency	$f_T$	$V_{CE}=6\text{V}, I_C=20\text{mA},$ $f=30\text{MHz}$	150			MHz
Collector output capacitance	$C_{OB}$	$V_{CB}=10\text{V}, I_E=0, f=1\text{MHz}$			5	pF

Classification of  $h_{FE}$

Rank	L	H	J
Range	120~200	200~350	300~400

## 5. Typical Characteristic

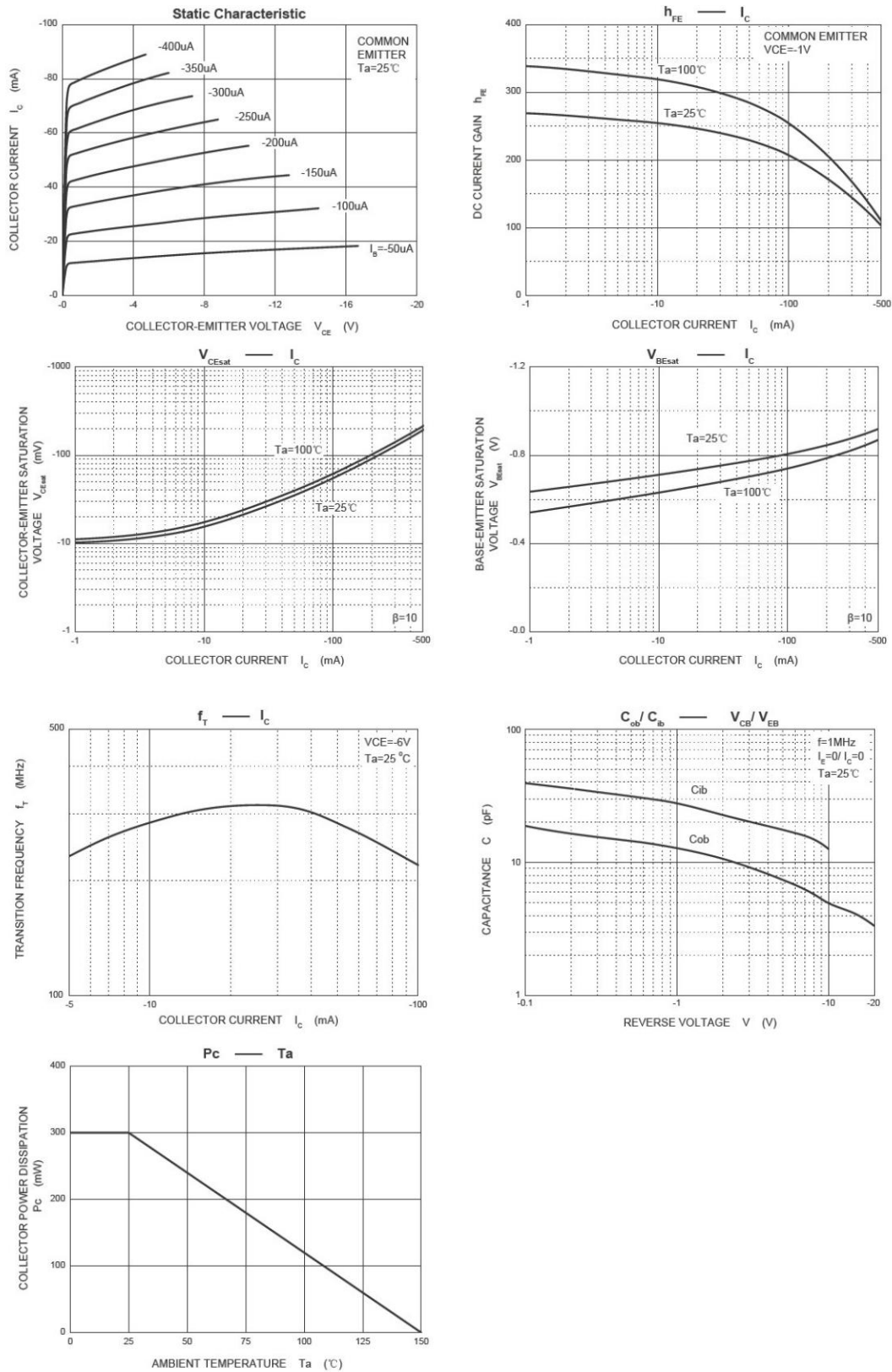

6. Dimension and Patterns (SOT-23)

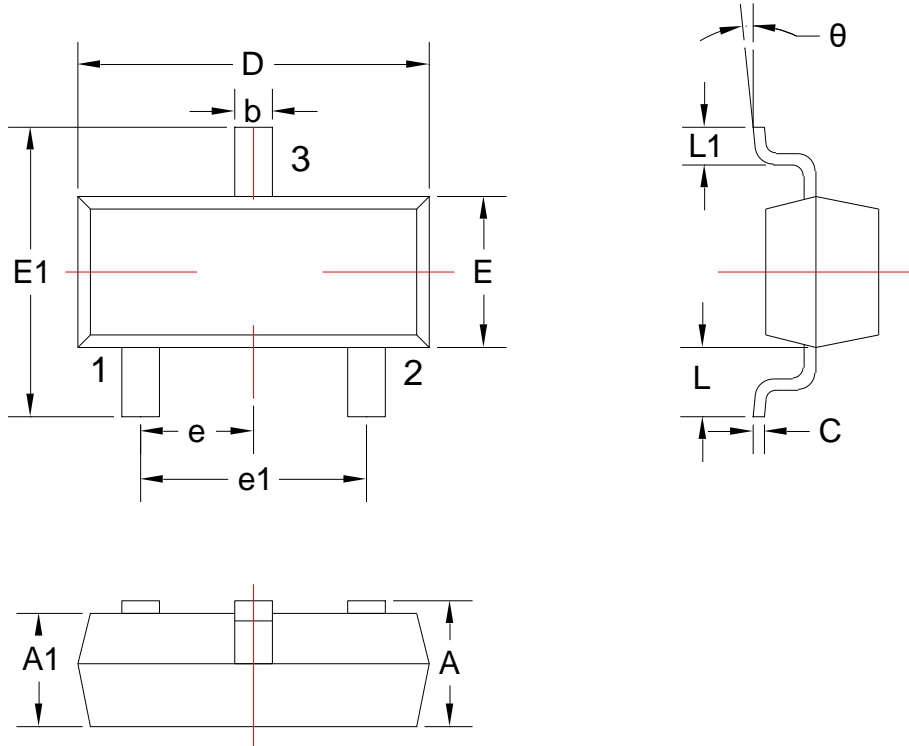

Units: mm

Symbol	Dimensions		Symbol	Dimensions	
	Min.	Max.		Min.	Max.
A	0.900	1.150	E1	2.250	2.550
A1	0.900	1.050	e	0.950TYP	
b	0.300	0.500	e1	1.800	2.000
c	0.080	0.150	L	0.550REF	
D	2.800	3.00	L1	0.300	0.500
E	1.200	1.400	θ	0°	8°

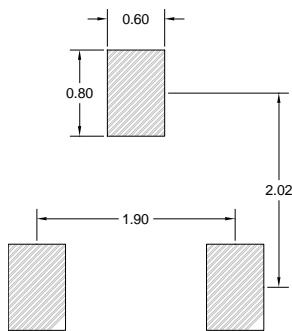

Note:

1. Controlling dimension: in millimeters
2. General tolerance:  $\pm 0.05\text{mm}$
3. The pad layout is for reference only
4. Unit: mm